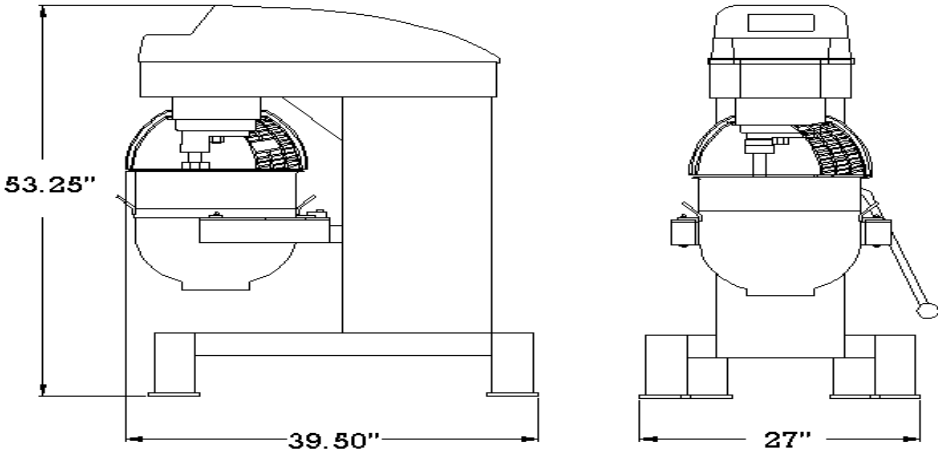

American Baking Systems

Planetary Mixer

Specifications Sheet

Model: ABSPMS-40L

<p><u>RPM's:</u></p> <p>1st Speed : 125 ↓ ↓ 10th Speed : 424</p> <p><u>Capacities:</u></p> <p>Liquid: 40 Quarts Flour: 25.2 Pounds</p> <p><u>Optional:</u> 20 Quart attachments</p>	
--	--

Electrical: 208/220 Volt 3 Phase 60 Hz 8 Amps 2 HP. Supplied with Twist-Lock plug. Recommend a 15 Amp slow-blow breaker. Plug: NEMA L 15-20 P

Spacing: 12" from wall in rear. Access to remaining sides for operation, right side for bowl lock lever allow at least 20-inches.

Features: Stainless steel bowl, whip, dough hook, paddle and pour spout. Digital Control Panel with 10-speeds and shift on-the-fly. Timed and untimed operation.

Shipping: Weight: 900 pounds, freight class: 85. Fully crated dims: 45" D x 35" W x 58" H

Notes

- All Dimensions are in inches and are approximate.
- Specifications are subject to change without notice.



Meets UL 763 and NSF-8 Standards

Distributed by:



AMERICAN BAKING SYSTEMS, INC.
290 LEGION COURT S.W.
CEDAR RAPIDS, IA 52404
Phone: 319-373-5006
Fax: 319-373-5008
Email: INFO@ABS1.NET
WEB: www.abs1.net