

## Specifications Sheet

**Floor Model: ABSRDS-8.5/24  
ABSRDS-10/24**

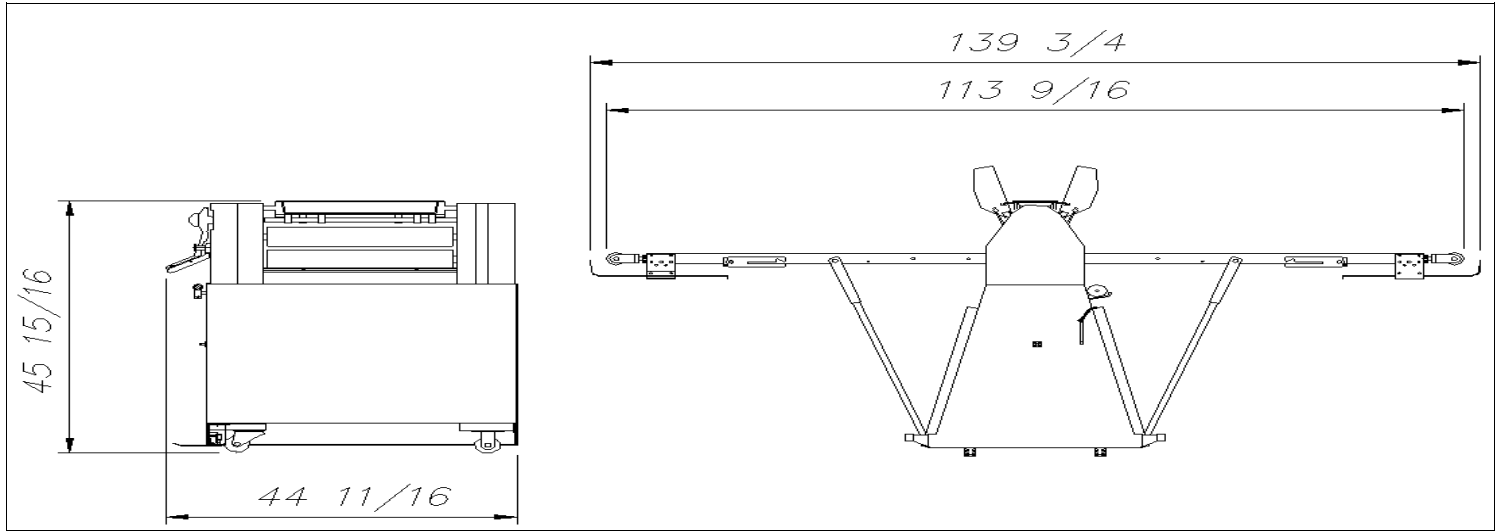

**Electrical:** 208/220 Volt 3 Phase 60 Hz 12 Amps. Supplied with twist-lock plug. Recommend a 15 Amp slow-blow breaker. Plug: NEMA L15-20P

**Spacing:** 0" from wall in rear. Access to remaining sides for operation, front for operation of controls.

**Features:** Stainless steel panels and aluminum construction. Hand and foot controls. Seamless belts. Catch trays at both ends. Baton is standard.

**Shipping:** Weight: 745 pounds, Freight class: 85. Fully crated dims: 47" D x 61" W x 52" H

## Notes

- All Dimensions are in inches and are approximate.
- Specifications are subject to change without notice.



Meets UL 763 and NSF-8 Standards

Distributed By:



AMERICAN BAKING SYSTEMS, INC.  
290 LEGION COURT S.W.  
CEDAR RAPIDS, IA 52404  
Phone: 319-373-5006  
Fax: 319-373-5008  
Email: INFO@ABS1.NET  
WEB: www.abs1.net