

Reversible Dough Sheeter

Model
ABSTTS-20

TABLE MODEL



**American Baking Systems offers a Table-top Dough Sheeter
for Bakeries, Supermarkets and Pastry shops.**

- *Bakery Equipment*
- *Consulting*
- *Design*



AMERICAN BAKING SYSTEMS,
INC.
290 LEGION COURT S.W.
CEDAR RAPIDS, IA 52404
Phone: 319-373-5006
Fax: 319-373-5008

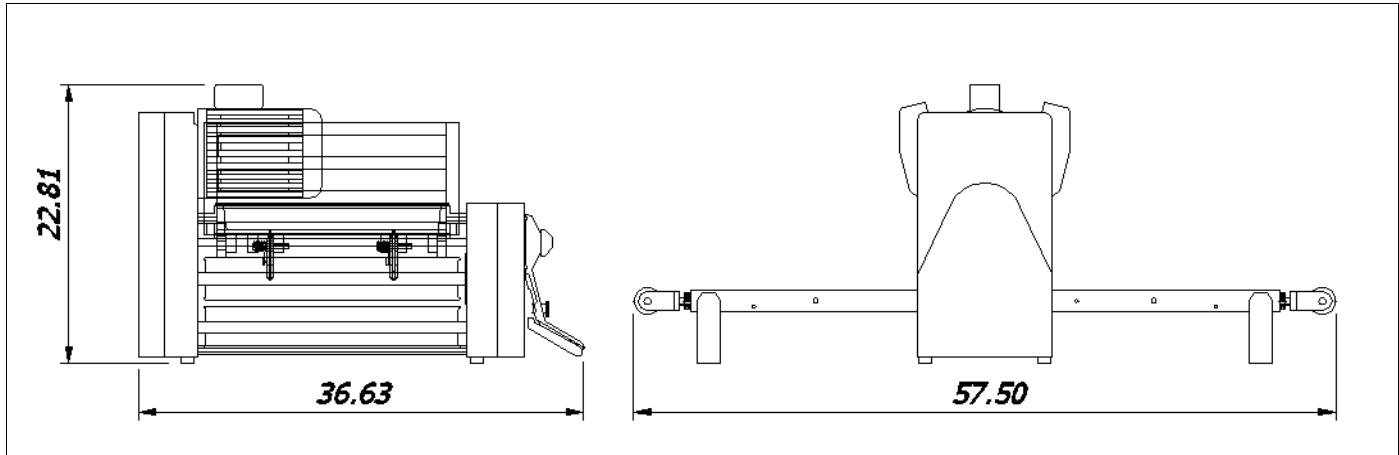

Electrical: 208/220 Volt 3 Phase 60 Hz 12 Amps. Supplied with twist-lock plug. Recommend a 15 Amp slow-blow breaker. Plug: NEMA L15-20P

Spacing: 0" from wall in rear. Access to remaining sides for operation, front for operation of controls.

Features: Stainless steel panels and aluminum construction. Hand controls. Seamless belts. Baton is standard. Tables fold up for cleaning and storage.

Shipping: Weight: 400 pounds, Freight class: 85. Fully crated dims: 22" D x 40" W x 32" H

Notes

- All Dimensions are in inches and are approximate.
- Specifications are subject to change without notice.



Meets UL 763 and NSF-8 Standards

Distributed By:



AMERICAN BAKING SYSTEMS, INC.
290 LEGION COURT S.W.
CEDAR RAPIDS, IA 52404
Phone: 319-373-5006
Fax: 319-373-5008
Email: INFO@ABS1.NET
WEB: www.abs1.net