

Planetary Mixer 10-Quart Three-Speed Gear Driven ABSPMS-100CH



American Baking Systems offers a Three-Speed, High-torque, Gear-driven Planetary Mixer, which is designed for Bakeries, Supermarkets, and Restaurants.

- *Bakery Equipment*
- *Consulting*
- *Design*



AMERICAN BAKING SYSTEMS, INC.
290 LEGION COURT S.W.
CEDAR RAPIDS, IA 52404
Phone: 319-373-5006
Fax: 319-373-5008
Email: INFO@ABS1.NET

Features

- Solid cast steel construction
- Three Speeds with clutch
- Full bowl cover for safety
- Batter Capacity: 10 lbs
- Dough Capacity: 8 lbs @ 60%
6 lbs @ 55%
- Stainless steel bowl, wire whip and dough hook.
- Stainless steel pour spout.
- Aluminum paddle
- Attachment hub standard.
- ETL meets UL 763 standards
- ETL–Sanitation meets NSF 8 standards

Specifications

(Speed)	FIRST	SECOND	THIRD
(RPM)	104	217	356

Electrical Specifications

VOLTS	PHASE	Hz	AMPS	kW	HP
120	1	60	12	.37	.5

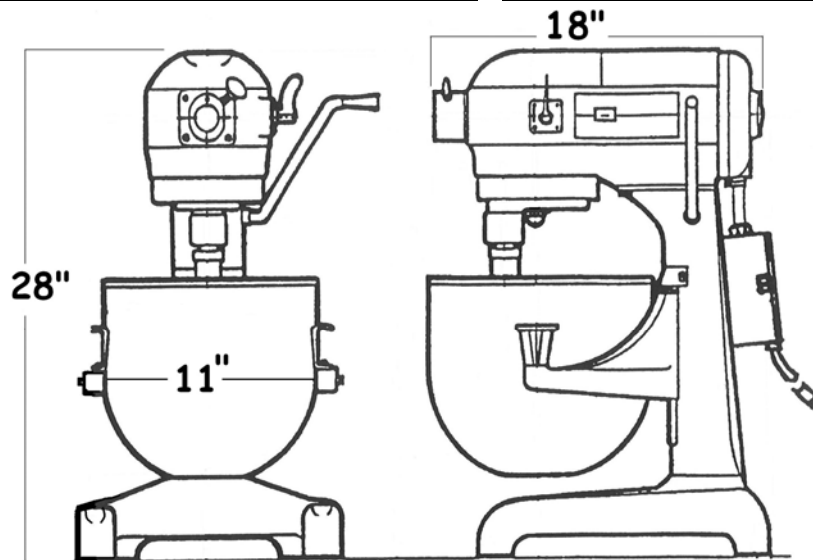

Dimensions: 28" High x 18" Deep x 16" Wide

Weight of Mixer: 147 pounds.

NOTES:

- Supplied with 6-foot cord with Grounding plug
- 100CH machine is supplied with bowl, hook, paddle, and whip
- OPTION: Stainless Steel Table for mounting unit up off of floor
- Shipping Weight: 185 Pounds, Freight class 85
- All dimensions are in inches and are approximate.
- Specifications are subject to change without notice.



Distributed by:



AMERICAN BAKING SYSTEMS, INC.
290 LEGION COURT S.W.
CEDAR RAPIDS, IA 52404
Phone: 319-373-5006
Fax: 319-373-5008
Email: INFO@ABS1.NET