

## Features

- Solid cast steel construction
- Three Speeds with clutch
- Full bowl cover for safety
- Batter Capacity: 20 lbs
- Dough Capacity: 20 lbs @ 60%  
   15 lbs @ 55%
- Stainless steel bowl, wire whip and dough hook.
- Stainless steel pour spout.
- Aluminum paddle
- Attachment hub standard.
- ETL meets UL 763 standards
- ETL–Sanitation meets NSF 8 standards

## Specifications

(Speed)	FIRST	SECOND	THIRD
(RPM)	105	194	354

## Electrical Specifications

VOLTS	PHASE	Hz	AMPS	kW	HP
120	1	60	12	.9	1

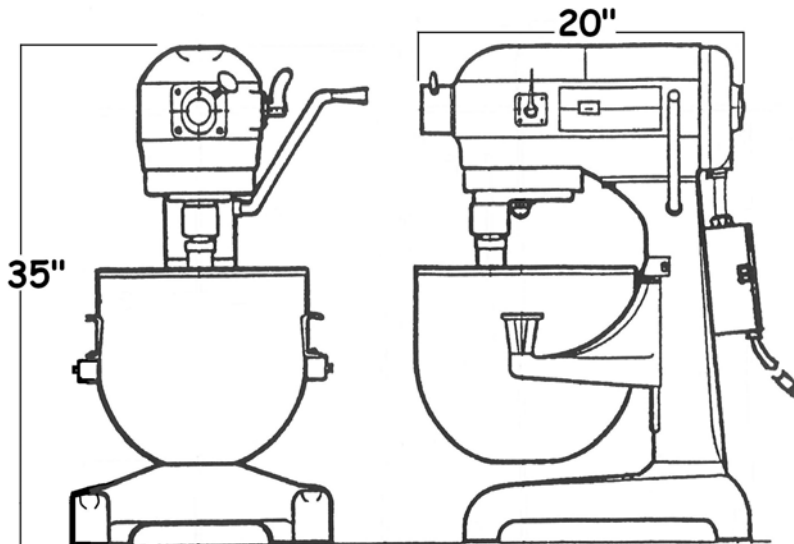

Dimensions: 35" High x 20" Deep x 17" Wide

Weight of Mixer: 222 pounds.

## NOTES

- Supplied with 6-foot cord with Grounding plug
- 200CH machine is supplied with bowl, hook, paddle, and whip
- OPTION: Stainless Steel Table for mounting unit up off of floor
- Shipping Weight: 300 Pounds, Freight class 85
- All dimensions are in inches and are approximate.
- Specifications are subject to change without notice.



Distributed by:



AMERICAN BAKING SYSTEMS, INC.  
 290 LEGION COURT S.W.  
 CEDAR RAPIDS, IA 52404  
 Phone: 319-373-5006  
 Fax: 319-373-5008  
 Email: INFO@ABS1.NET