

Features

- Solid cast steel construction
- Three Speeds with clutch
- Full bowl cover for safety
- Batter Capacity: 30 lbs
- Dough Capacity: 25 lbs @ 60%
20 lbs @ 55%
- Stainless steel bowl, wire whip and dough hook.
- Stainless steel pour spout.
- Aluminum paddle
- Attachment hub standard.
- ETL meets UL 763 standards
- ETL–Sanitation meets NSF 8 standards

Specifications

(Speed)	FIRST	SECOND	THIRD
(RPM)	107	190	366

Electrical Specifications

VOLTS	PHASE	Hz	AMPS	kW	HP
208/220	3	60	10	1.2	1

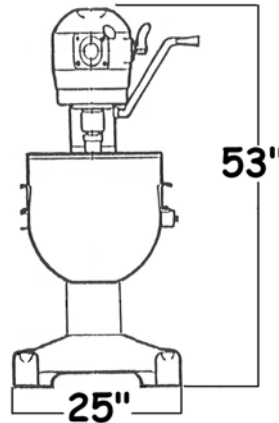
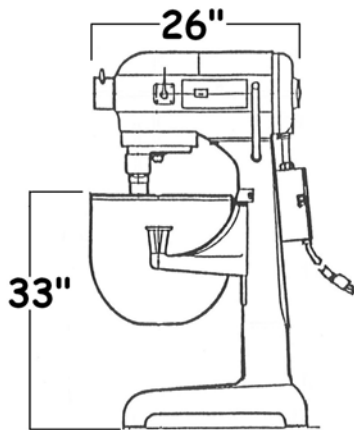

Dimensions: 53" High x 26" Deep x 25" Wide

Weight of Mixer: 425 pounds.

NOTES:

- Supplied with 6-foot cord with Grounding plug
- 300CH machine is supplied with bowl, hook, paddle, and whip
- Shipping Weight: 515 Pounds, Freight class 85
- All dimensions are in inches and are approximate.
- Specifications are subject to change without notice.



Distributed by:



AMERICAN BAKING SYSTEMS, INC.
290 LEGION COURT S.W.
CEDAR RAPIDS, IA 52404
Phone: 319-373-5006
Fax: 319-373-5008
Email: INFO@ABS1.NET